

This article was downloaded by:

On: 24 January 2011

Access details: *Access Details: Free Access*

Publisher *Taylor & Francis*

Informa Ltd Registered in England and Wales Registered Number: 1072954 Registered office: Mortimer House, 37-41 Mortimer Street, London W1T 3JH, UK



Journal of Liquid Chromatography & Related Technologies

Publication details, including instructions for authors and subscription information:

<http://www.informaworld.com/smpp/title~content=t713597273>

Development of Automated Highly Sensitive Analytical System for Guanethidine Sulfate in Serum

Yukiko Inamoto^a; Shigeyuki Inamoto^a; Toshihiko Hanai^b; Yuichiro Takahashi^c; Kazuomi Kadowaki^d; Toshio Kinoshita^e

^a Research & Development Teikoku Seiyaku Co., Ltd., Kagawa, Japan ^b International Institute of Technological Analysis Health Research Foundation, Institut Pasteur de Kyoto, Kyoto, Japan ^c Jinken Clinic, Kanagawa, Japan ^d Department of Urology, Kitasato Institute Hospital, Tokyo, Japan ^e School of Pharmaceutical Sciences Kitasato University, Tokyo, Japan

To cite this Article Inamoto, Yukiko , Inamoto, Shigeyuki , Hanai, Toshihiko , Takahashi, Yuichiro , Kadowaki, Kazuomi and Kinoshita, Toshio(1997) 'Development of Automated Highly Sensitive Analytical System for Guanethidine Sulfate in Serum', *Journal of Liquid Chromatography & Related Technologies*, 20: 13, 2099 — 2108

To link to this Article: DOI: 10.1080/10826079708005568

URL: <http://dx.doi.org/10.1080/10826079708005568>

PLEASE SCROLL DOWN FOR ARTICLE

Full terms and conditions of use: <http://www.informaworld.com/terms-and-conditions-of-access.pdf>

This article may be used for research, teaching and private study purposes. Any substantial or systematic reproduction, re-distribution, re-selling, loan or sub-licensing, systematic supply or distribution in any form to anyone is expressly forbidden.

The publisher does not give any warranty express or implied or make any representation that the contents will be complete or accurate or up to date. The accuracy of any instructions, formulae and drug doses should be independently verified with primary sources. The publisher shall not be liable for any loss, actions, claims, proceedings, demand or costs or damages whatsoever or howsoever caused arising directly or indirectly in connection with or arising out of the use of this material.

DEVELOPMENT OF AUTOMATED HIGHLY SENSITIVE ANALYTICAL SYSTEM FOR GUANETHIDINE SULFATE IN SERUM

Yukiko Inamoto,¹ Shigeyuki Inamoto,¹ Toshihiko Hanai,²
Yuichiro Takahashi,³ Kazuomi Kadowaki,⁴ Toshio Kinoshita⁵

¹Research & Development
Teikoku Seiyaku Co., Ltd.
567 Sanbonmatu, Ochi-Cho, Okawa-Gun
Kagawa 769-26 Japan

²International Institute of Technological Analysis
Health Research Foundation
Institut Pasteur de Kyoto, 5F
Hyakumanben, Sakyo-Ku
Kyoto 606 Japan

³Jinken Clinic
1-8-6 Chuo, Ebina-shi
Kanagawa, 243-04 Japan

⁴Kitasato Institute Hospital
Department of Urology
9-1 Shirokane-5, Minato-ku
Tokyo 108 Japan

⁵School of Pharmaceutical Sciences
Kitasato University
9-1, Shirokane-5, Minato-Ku
Tokyo 108 Japan

ABSTRACT

An automated trace analytical system for guanethidine sulfate in sera was developed using a liquid chromatograph with column-switching and post-column reaction detection systems. Guanethidine sulfate was post-labeled with ninhydrin in alkaline solution, and the reaction products were monitored with a fluorescence detector. Guanethidine sulfate, an antihypertensive agent, in rat and human sera was analyzed using this automated analyzer. The detection limit of guanethidine sulfate was 1.0 ng/mL, and the calibration curve was linear from 3.1 ng/mL to 1000 ng/mL with relative standard deviation of less than 3%. The recovery from sera was $99.7 \pm 3.9\%$.

INTRODUCTION

Guanethidine sulfate, 1-[2-(1-perhydroazocinyl) ethyl] guanidine monosulfate, is an antihypertensive agent usually administered orally to patients with essential hypertension. Also, this drug is a selective inhibitor of the sympathetic nervous system at the postganglionic terminal of the adrenergic neuron. Hannington-Kiff¹ first reported the use of guanethidine for the treatment of reflex sympathetic dystrophy. Since then, there have been numerous reports regarding the effectiveness of intravenous regional block of guanethidine.²⁻⁴ Sharpe et al.⁵ reported a case of severe and persistent hypotension which occurred after a repeated guanethidine block, and concluded that a careful monitoring of the cardiovascular system is important to prevent a prolonged hypotension. Therefore, a rapid, and sensitive analytical method for guanethidine sulfate is required for monitoring its concentration in patients' sera and for determination of bioavailability of different preparations.

Several methods have been reported for the determination of guanidine such as oxidimetry,⁶ complexometry,⁷ calorimetry,⁸⁻¹⁰ fluorometry,¹¹⁻¹² and liquid chromatography.¹³⁻¹⁶ Gas chromatography, after selective extraction, was used for determination in biological fluids.¹⁷ Guanethidine sulfate, in tablets and biological fluids, was analyzed by a spectrofluorometric method using the condensation reaction of the guanidino group with 9,10-phenanthraquinone,¹⁸ and with benzoin.¹⁹ The official method²⁰ for assaying of guanethidine sulfate is based on colorimetry of the guanidino group with sodium nitroferricyanide and potassium ferricyanide. However, the disadvantage of this method is the time-consuming, selective extraction procedures and the low sensitivity.

Hiraga and Kinoshita²¹ developed a post-column high performance liquid chromatography method with fluorometric detection, based on the detection of intense fluorescence produced using a reaction of guanidino base and ninhydrin under alkaline conditions. We modified this method and connected an on-line pre-treatment column for the selective extraction of guanethidine sulfate from sera.

Here, we describe the details and performance of our newly developed analytical system for guanethidine sulfate analysis, based on a liquid chromatograph with automated column-switching and post-column reaction fluorometric detection. This system was applied for analysis of guanethidine sulfate in rat and human sera.

EXPERIMENTAL

Materials and Methods

Guanethidine monosulfate was purchased from Sigma Chemical Co. Ltd. (St. Louis, MO, U.S.A.). Ion pair reagents were purchased from Nacalai Tesque, Inc. (Kyoto, Japan). All other chemicals were purchased from Wako Chemical Co. Ltd. (Tokyo, Japan). Blood samples, collected from rat and human, were centrifuged at 1,000 g for 15 min at room temperature and the supernatant was directly injected into this analytical system.

Chromatography

Figure 1 shows the flow diagram of the automated analytical system based on a liquid chromatograph with a column-switching and a post-column reaction detector. Eluent 1 consisted of 50 mM sodium dihydrogenphosphate (pH 3.0 adjusted with 50 mM phosphoric acid). Eluent 2 consisted of acetonitrile and 50 mM sodium dihydrogenphosphate (pH 3.0 adjusted with 50 mM phosphoric acid) (30:70, v/v) containing sodium 1-octanesulfonate (7 g/L). Eluent 3 was aqueous acetonitrile (500 ml/L).

Eluent 1 was discarded after passing through the column switching valve MV, Model MV-8010 (Tosoh, Tokyo, Japan) and pre-column I (TSK precolumn BSA-ODS; 35 mm x 4.6 mm I.D., 10 μ m, Tosoh).

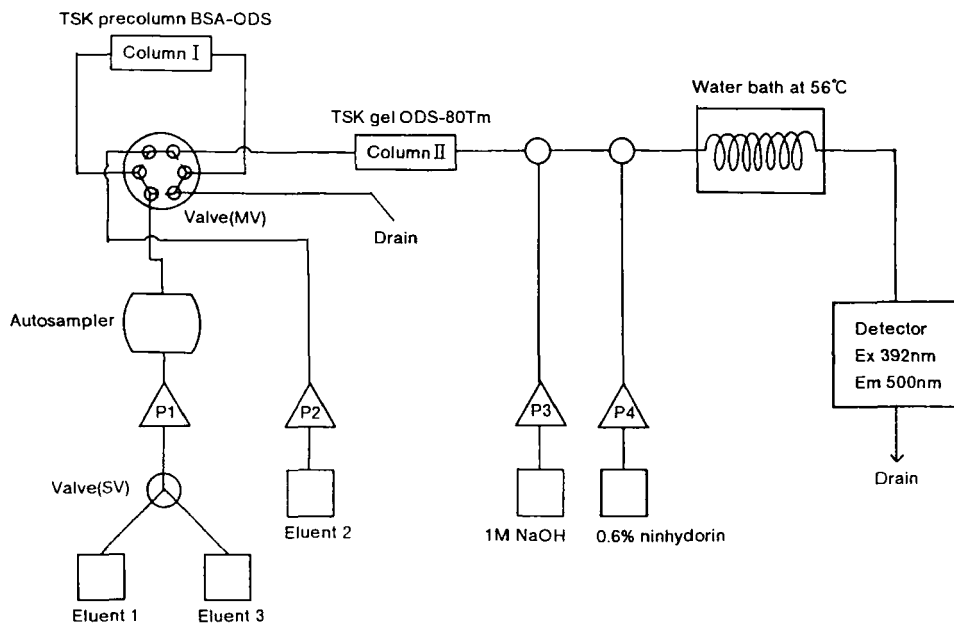

Figure 1. Flow diagram of the automated guanethidine analyzer based on a liquid chromatograph with column-switching and post-column reaction systems.

Eluent 2 flowed through the switching valve to the analytical column II (TSKgel ODS-80TM; 150 mm x 4.6 mm I.D., 5 μ m, Tosoh) and a spectrofluorometric detector, Model FS-8010 (Tosoh), then to waste in that order. The flow rate of eluents 1 and 2 were 1.0 mL/min regulated with two Model CCPM (Tosoh) pumps.

Aliquots of serum samples, each 200 μ L, were directly injected into column I using an autosampler, Model AS-8000 (Tosoh), where they were trapped and rinsed with eluent 1. Guanethidine sulfate was separated from the interfering substances and proteins in serum on pre-column I. Two minutes after injection, samples were transferred from pre-column I to column II with eluent 2 by turning valve MV. Valve MV was then returned to the original position after 5 min. At 15 min after sample injection, pre-column I was rinsed with eluent 3 at a flow-rate of 1.0 mL/min. For 15-22 min, eluent 3 in pre-column I was replaced with eluent 1, returning to the initial conditions, by switching valve SV (Model SV-8010, Tosoh).

On the other hand, eluent 2 passed through MV and column II during analysis, and passed from pre-column I to column II over a period of 2-5 min via MV. Guanethidine sulfate was separated on column II.

Post-column derivatization was accomplished as follows: Aqueous ninhydrin solution (6 g/L) and 1 M sodium hydroxide were delivered from two reagent pumps (Model 885-PU, Japan Spectroscopic, Tokyo, Japan), at flow-rates of 0.3 mL/min. The effluent from column II was first mixed with 1 M sodium hydroxide, then mixed with aqueous ninhydrin solution (6 g/L). The mixture was heated in a reaction coil (Teflon™ tube, 10 m x 0.5 mm I.D.), placed in a water-bath at 56°C, and the reaction products were monitored at Ex 392 nm and Em 500 nm with a spectrofluorometric detector.

Animal Experiments

Male wistar rats, weighing 250-280 g, were fasted for 18h before experiments. Guanethidine sulfate in saline was administered to rats intramuscularly. Blood samples were taken from the right jugular vein before, as well, as 15, 30, 60 and 120 min after administration. The amounts of guanethidine sulfate in their sera were analyzed quantitatively.

RESULTS

The excitation and fluorescence maxima obtained from the reaction products were 392 nm and 500 nm, respectively. Post-column derivatization was performed by injecting 10 µL of standard solution of guanethidine sulfate (5 µg/L) using a flow injection method. The effluent was allowed to react with reagents containing various concentrations of ninhydrin (1-10 g/L) and sodium hydroxide (0.5-1.5 M) at a flow rate of 0.3 mL/min, passing through a heating device set at various temperatures (30-70°C), and the fluorescence intensity of the reaction products was measured with a spectrofluorometric detector. The fluorescence intensities reached plateaus at the ninhydrin and sodium hydroxide concentrations of 5 g/L and 0.8 M, respectively. The fluorescence increased with increasing reaction temperature and reached a maximum at 56°C. In the standard procedure, an aqueous solution containing ninhydrin (6 g/L) and 1 M sodium hydroxide was adopted as the reaction reagent, and the reaction temperature was 56°C.

A pretreatment method, to clean up samples and for separation of guanethidine sulfate, was examined using rat serum. A TSK precolumn BSA-ODS (bovine serum albumin-coated ODS column; 35 mm x 4.6 mm I.D.,

particle size 10 μm) and a TSK precolumn SW (hydrophilic silica gel column; 35 mm x 4.6 mm I.D., particle size 15 μm) were examined as pre-column I for sample clean-up. A good separation of guanethidine sulfate from the interfering substances and proteins in serum was achieved using the TSK precolumn BSA-ODS. Retention of guanethidine sulfate on pre-column I and separation from the interfering substances were influenced by the pH of sodium phosphate buffer. The final solution for eluent 1 was 50 mM sodium phosphate solution, pH3.0.

Guanethidine sulfate concentrated on pre-column I was eluted with eluent 2, and the effluent was transferred to column II (TSKgel ODS-80TM) for further separation. The effects of ion-pair reagents were examined to separate the drug from the interfering substances in the effluent on column II. The best separation was achieved in acetonitrile and 50 mM sodium dihydrogenphosphate (pH 3.0, adjusted with 50 mM phosphoric acid) 30:70, v/v mixture containing sodium 1-octanesulfonate (7 g/L).

Under these conditions, a chromatogram of human serum was shown in Fig. 2. No compounds were found to interfere in the quantitative analysis of guanethidine. The calibration curve for guanethidine sulfate was linear, in the range from 3.1 to 1000 ng/mL in human serum. The peak area was related to the amount of guanethidine sulfate in human serum. The relationship was $y = 0.8424x - 0.7818$ ($r = 0.9999$). The detection limit of guanethidine sulfate was 1.0 ng/mL ($S/N = 3$). The reproducibility of this procedure was sufficient, and the coefficient of variation for 50 ng/mL guanethidine sulfate in human serum was 2.6 % ($n=100$). The recoveries from human serum were around $99.7 \pm 3.9\%$ ($n=40$).

The solutions of guanethidine sulfate in saline were administered to rats intramuscularly. Figure 3 showed the dose-response profiles of serum guanethidine sulfate levels in rats. The changes in guanethidine sulfate in rat serum were dose-dependent.

DISCUSSION

In the newly developed analytical system for the determination of guanethidine sulfate in serum, sample treatment is very simple requiring only one centrifugation step. The supernatant is automatically cleaned up with a column-switching method, separated, and the guanethidine derivatives undergo post-column derivatization and are quantified with a fluorescence detector.

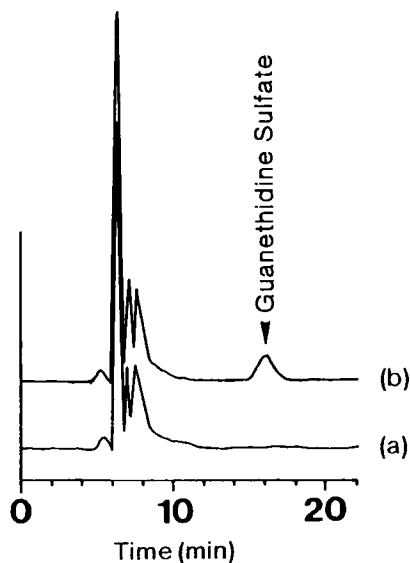

Figure 2. Chromatograms of guanethidine sulfate spiked to human serum: (a) control and (b) spiked.

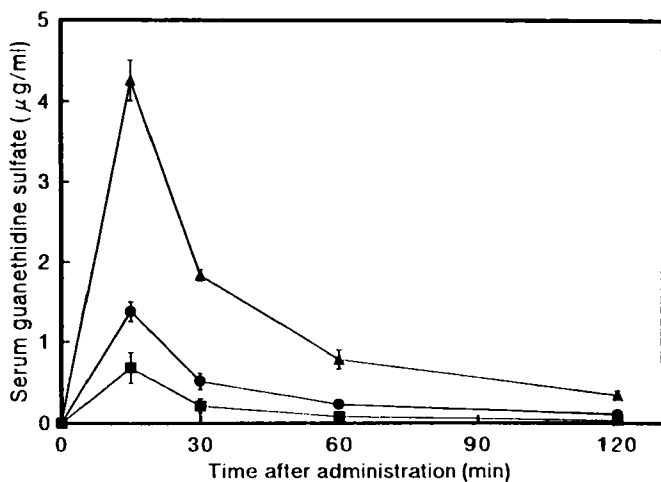

Figure 3. Dose-dependency of serum guanethidine sulfate levels following intramuscular administration to rats. Intramuscular administration: (■) 2, (●) 4, (▲) 10 mg/kg. Each point is the mean \pm S.D. of 5 animals.

Guanethidine sulfate uniquely targets to the peripheral sympathetic nervous system. The adrenergic blocking effects of guanethidine sulfate requires presence of the drug in adrenergic neurons; the degree of adrenergic blockade is a function of the plasma concentration of guanethidine under normal conditions.²² Adrenergic neuronal blockade is generally accomplished by plasma concentrations greater than 10 $\mu\text{g/L}$. After a single oral dose of 41mg guanethidine-¹⁴C, the maximum blood concentration of uncharged guanethidine was 22 $\mu\text{g/L}$,²³ and half-life was diphasic; 1.5 days and from 4.1 to 7.7 days.²⁴ Guanethidine bioavailability was incomplete and variable among individual subjects. Only 3 to 50 % of an oral-dose reached the systemic circulation.^{23,25,26} Such variation might be attributable to individual differences in enteric absorption, first-pass metabolism, or renal clearance of guanethidine.

A significant correlation was also observed between the area under the plasma level curve during the dose interval and the oral maintenance dose.²⁴ With regard to administration of guanethidine sulfate in patients, those with renal failure show orthostatic hypotension because of decreased renal blood flow and depression of renal excretion. A stronger antihypertensive action causes a depression of metabolic function in aged patients. Therefore, it is desirable to quantify serum concentration of guanethidine sulfate in patients to determine appropriate dosage and dosing interval as well as to avoid side-effects.

In conclusion, this method is simple, rapid, and sensitive, and is therefore expected to be clinically useful for monitoring the concentration of guanethidine sulfate in patients.

REFERENCES

1. J. G. Hannington-Kiff, *Lancet*, 8022, 1132-1133 (1977).
2. J. Driessen, C. Van Der Werken, P. A. Nicolai, J. F. Crul., *Acta Anaesthesiol. Scand.*, 27, 505-509 (1983).
3. A. G. Rocco, A. F. Kaul, R. M. Reisman, J. P. Gallo, P. A. Lief, *Clin. J. Pain*, 5, 205-209 (1989).
4. S. Ramamurthy, J. Hoffman, the Guanethidine Study Group, *Anesth. Analg.*, 81, 718-723 (1995).
5. E. Sharpe, R. Milaszkiwicz, F. Carli, *Anaesthesia*, 42, 1081-1084 (1987).

6. I. Ganescu, G. Brizan, C. Verhelyi, *Chem. Anal. (Warsaw)*, **29**, 549-553 (1984).
7. E. Zollnernevan, *Acta Pharm. Hung.*, **48**, 76-84 (1978).
8. I. Ganescu, I. Papa, M. Preda, *Pharmazie*, **40**, 495 (1985).
9. G. R. Rao, S. Raghuveer, *Indian J. Pharm. Sci.*, **42**, 141-142 (1980).
10. S. Tanabe, T. Oya, T. Sakaguchi, *Chem. Pharm. Bull.*, **23**, 1657-1663 (1975).
11. M. A. Parniak, G. Lange, T. Viswanatha, *J. Biochem. Biophys. Methods*, **7**, 267-276 (1983).
12. M. Kai, T. Miura, K. Kohashi K., Y. Ohkura, *Chem. Pharm. Bull.*, **29**, 1115-1120 (1981).
13. Y. Kobayashi, H. Kubo, T. Kinoshita, *Anal. Sci.*, **3**, 363-367 (1987).
14. M. Kai, T. Miyazaki, Y. Ohkura, *J. Chromatogr.*, **311**, 257-266 (1984).
15. J. T. Stewart, S. S. Clark, *J. Pharm. Sci.*, **75**, 413-415 (1986).
16. Y. Golander, U. Schurrath, R. J. Luck, *J. Pharm. Sci.*, **77**, 902-905 (1988).
17. J. H. Hengstmann, F. C. Falkner, J. T. Watson, J. Oates, *Anal. Chem.*, **46**, 34-38 (1974).
18. M. H. Abdel-Hay, S. M. Galal, M. M. Bedair, A. A. Gazy, A. A. M. Wahbi, *Talanta* **39**, 1369- 1375 (1992).
19. A. M. Wahbi, M. M. Bedair, S. M. Galal SM., M. H. Abdel-Hay, A. A. Gazy, *Mikrochim. Acta*, **111**, 83-91 (1993).
20. Guanethidine monosulfate, USP XXII, 1990, pp. 623-624.
21. Y. Hiraga, T. Kinoshita, *J. Chromatogr.*, **342**, 269-275 (1985).
22. I. E. Waiter, J. Khandelwal, F. Falkner, A. S. Nies, *Clin. Pharmacol. Ther.*, **18**, 571-580 (1975).

23. K. H. Rahn, L. I. Goldberg, *Clin. Pharmacol. Ther.*, **10**, 858-866 (1969).
24. J. H. Hengstmann, F. C. Falkner, *Europ. J. Clin. Pharmacol.*, **15**, 121-125 (1979).
25. C. Mcmartin C., P. Simpson, *Clin. Pharmacol. Ther.*, **12**, 73-77 (1971).
26. G. Lukas, *Drug Metab. Rev.*, **2**, 101-116 (1973).

Received August 20, 1996

Accepted September 6, 1996

Manuscript 4265